



Innovative Photonic Solutions

5420

LED CABI

CoAxial Beamsplitter Illuminator

KEY FEATURES

- CoAxial LED Lightsource
- Internal Current Regulation (No Burn-Out)
- Solid State Reliability
- High Intensity Output
- Multiple Color Options
- Visible & Infrared Options
- 100,000 Hour Operation
- Protective Dust Cover



Solid State Illuminator

The **5420** provides diffuse coaxial illumination through a beamsplitter allowing the camera to view the objects perpendicularly through the unit. The 5420 with its premature burn-out protection circuitry, contamination protection dust cover, and vibration resistant operation is a robust and reliable solid state lighting solution. The 5420 is suitable for a whole host of automated imaging applications. The unit is ready to run by simply supplying 24VDC through the environmentally protected connector. The 5400 series comes in a variety of standard spectral outputs to meet most requirements. Solid state technology means

no maintenance or relamping required for up to 10 years. Customized units are available for specialized wavelengths - contact factory for pricing and delivery info.

APPLICATIONS

- Machine Vision
- Semiconductors
- Electronics
- CD-Roms
- Printed Circuit Boards
- Surface Mount Components
- Leadframes
- Scribed, Indented and embossed feature enhancement

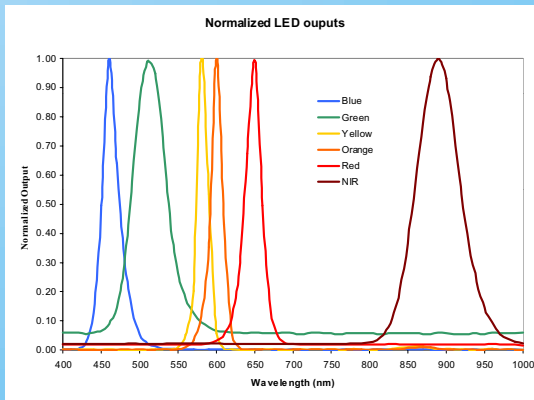

LED Wavelength Options

Detail Drawing

DXF file Available

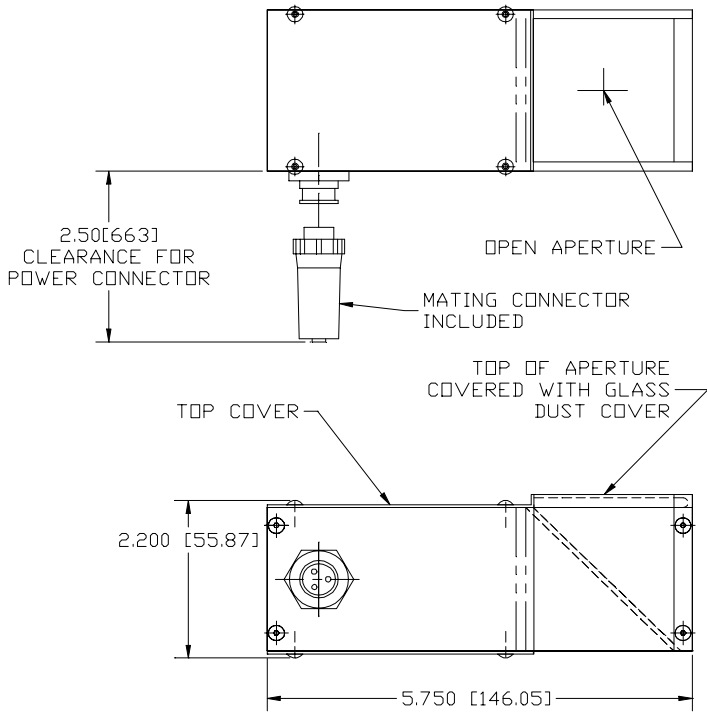

PART NUMBER	PEAK LIGHT OUTPUT
P/N 5420BL	430 nm NOMINAL
P/N 5420GRN	525 nm NOMINAL
P/N 5420ORG	612 nm NOMINAL
P/N 5420RED	660 nm NOMINAL
P/N 5420WHT	400 – 700 nm
P/N 5420YELL	595 nm NOMINAL

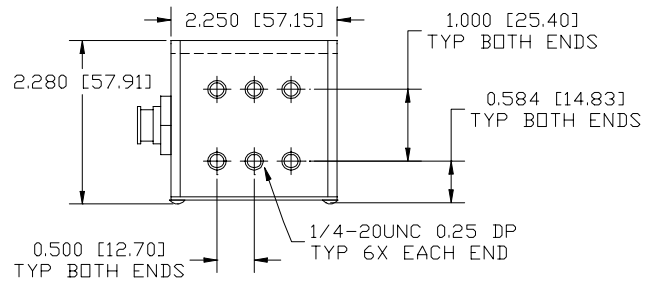

Technical Specifications

Physical

Height: 2.28" (57.91 mm)
 Width: 2.25" (57.15 mm)
 Length: 5.75" (146.1 mm)

Electrical

Input Voltage: 24 VDC
 Current Rating: 150 mA

Environmental

Temperature: 0 to 40C
 Rel Humidity: 0 to 95%

Wavelength Options

Red 660 nm
 Orange 612 nm
 Yellow 595 nm
 Green 525 nm
 Blue 470 nm
 NIR 880 nm

FOV Calculation

The Field of View for CABIs is **always** smaller than the Clear Aperture, and is a function of camera and CABI working distance. FOV is described by the formula shown here.

CA = Clear Aperture of CABI
 WD = Working Distance of the CABI (Object to Bottom of CABI)
 WDL = Working Distance of Camera (Object to Lens)

$$FOV = \frac{CA \times WDL}{CA + WD + WDL}$$

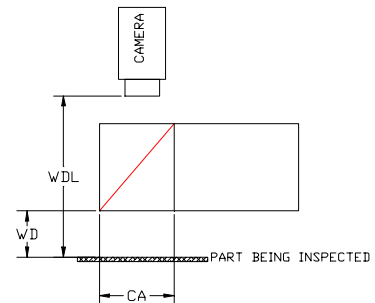

Proudly Distributed By:



Illumination Technologies, Inc.

5 Adler Drive 1 East Syracuse 1 New York 13057 USA
 TEL: 315-463-4673 1 FAX: 315-463-1401 1 Toll Free (North America): 800-738-4297
 Web: <http://www.illuminationtech.com> 1 E-mail: info@illuminationtech.com